

SUREFIRE™

FOUR BURNER GAS GRILL

Assembly/Installation Instructions and Use & Care Guide

For questions about features, operation/performance, parts call: 1-800-229-5647 or visit www.sureheat.com

Table of Contents.....2

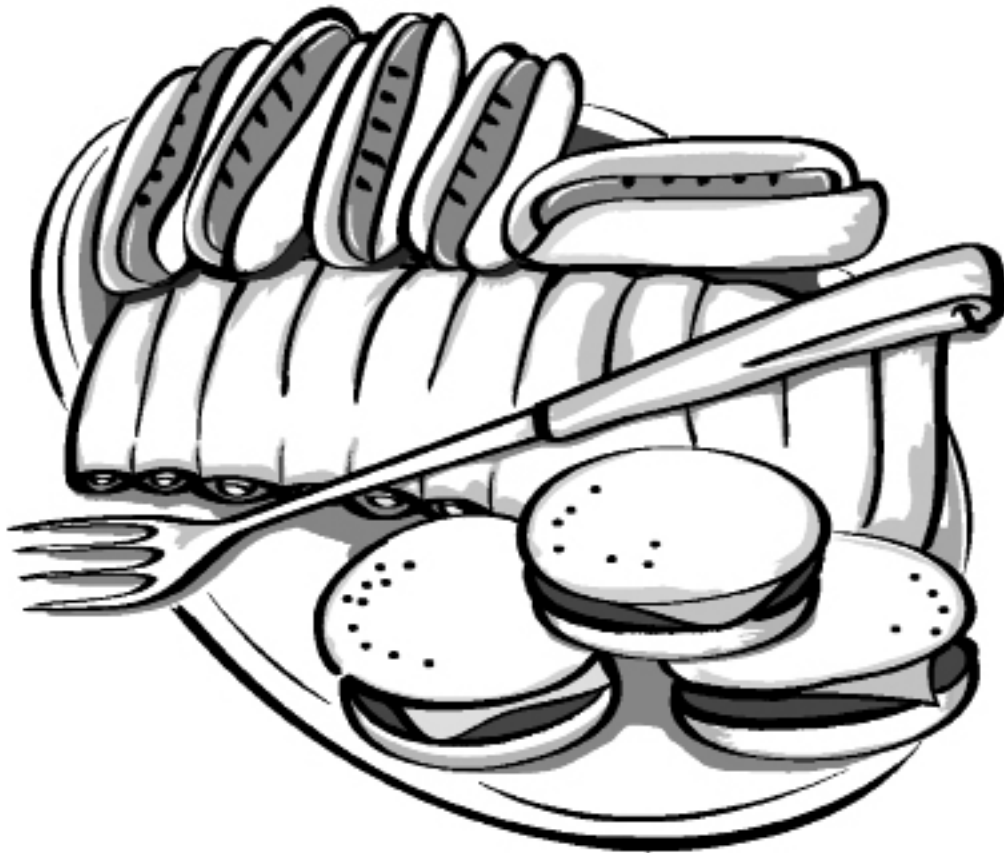

IMPORTANT:

Save for local inspector's use.

Installer: Leave installation instructions with the homeowner.

Homeowner: Keep installation instructions for future reference.

MODEL SF34LP

TABLE OF CONTENTS

OUTDOOR GRILL SAFETY	3
UNPACKING INSTRUCTIONS	5
ASSEMBLY REQUIREMENTS	5
Parts Supplied.....	5
ASSEMBLY INSTRUCTIONS	6
INSTALLATION REQUIREMENTS	11
Location Requirements	11
Gas Supply Requirements	11
Gas Connection Requirements.....	11
INSTALLATION INSTRUCTIONS	11
Make Gas Connection	11
Check the Burners	12
OUTDOOR GRILL USE	13
Using Your Outdoor Grill.....	13
Using Your Side Burner	14
TIPS FOR OUTDOOR GRILLING	15
Cooking Methods.....	15
OUTDOOR GRILL CARE	16
Replacing the Igniter Battery.....	16
General Cleaning.....	16
TROUBLESHOOTING	17
ASSISTANCE	17
REPLACEMENT PARTS	18
WARRANTY	21

OUTDOOR GRILL SAFETY

Your safety and the safety of others are very important.

We have provided many important safety messages in this manual and on your appliance. Always read and obey all safety messages.



This is the safety alert symbol.

This symbol alerts you to potential hazards that can kill or hurt you and others.

All safety messages will follow the safety alert symbol and either the word "DANGER" or "WARNING."

These words mean:

⚠ DANGER

You can be killed or seriously injured if you don't **immediately** follow instructions.

⚠ WARNING

You can be killed or seriously injured if you don't follow instructions.

All safety messages will tell you what the potential hazard is, tell you how to reduce the chance of injury, and tell you what can happen if the instructions are not followed.



DANGER

If you smell gas:

- 1. Shut off gas to the appliance.**
- 2. Extinguish any open flame.**
- 3. Open lid.**
- 4. If odor continues, keep away from the appliance and immediately call your gas supplier or your fire department.**



WARNING

- 1. Do not store or use gasoline or other flammable liquids or vapors in the vicinity of this or any other appliance.**
- 2. An LP cylinder not connected for use shall not be stored in the vicinity of this or any other appliance.**

State of California Proposition 65 Warnings:

- **WARNING:** This product contains a chemical known to the State of California to cause cancer.
- **WARNING:** This product contains a chemical known to the State of California to cause birth defects or other reproductive harm.

In the State of Massachusetts, the following installation instructions apply:

- Installations and repairs must be performed by a qualified or licensed contractor, plumber, or gas fitter qualified or licensed by the State of Massachusetts.
- If using a ball valve, it shall be a T-handle type.
- A flexible gas connector, when used, must not exceed 3 feet.

IMPORTANT: This grill is manufactured for outdoor use only. For grills that are to be used at elevations above 2000 ft (609.6 m) orifice conversion is required. See “Gas Supply Requirements” section. It is the responsibility of the installer to comply with the minimum installation clearances specified on the model/serial rating plate. The model/serial rating plate for this model is located inside the Access Door.

IMPORTANT SAFETY INSTRUCTIONS

WARNING: To reduce the risk of fire, electrical shock, injury to persons, or damage when using the outdoor cooking gas appliance, follow basic precautions, including the following:

- Do not install portable or built-in outdoor cooking gas appliances in or on a recreational vehicle, portable trailer, boat or in any other moving installation.
- Always maintain minimum clearances from combustible construction, see “Location Requirements” section.
- The outdoor cooking gas appliance shall not be located under overhead unprotected combustible construction.
- This outdoor cooking gas appliance shall be used only outdoors and shall not be used in a building, garage, or any other enclosed area.
- Keep any electrical supply cord and fuel supply hose away from any heated surfaces.
- Keep outdoor cooking gas appliance area clear and free from combustible materials, gasoline and other flammable vapors and liquids.
- Do not obstruct the flow of combustion and ventilation air. Keep the ventilation openings of the cylinder enclosure free and clear from debris.
- Inspect the gas cylinder supply hose before each use of the outdoor cooking gas appliance. If the hose shows excessive abrasion or wear, or is cut, it **MUST** be replaced before using the outdoor cooking gas appliance. Contact your dealer and use only replacement hoses specific for use with the outdoor cooking gas appliance.
- Visually check the burner flames. They should be blue. Slight yellow tipping is normal for LP gas.
- Check and clean burner/venturi tube for insects and insect nests. A clogged tube can lead to fire under the outdoor cooking gas appliance.
- The LP gas supply cylinder to be used must be:
 - constructed and marked in accordance with the Specification for LP Gas Cylinders of the U.S. Department of Transportation (DOT) or the National Standard of Canada, CAN/CSA-B339, Cylinders, Spheres and Tubes for Transportation of Dangerous Goods; and Commission.
 - provided with a listed overfilling prevention device.
 - provided with a cylinder connection device compatible with the connection for outdoor cooking gas appliances.
- Always check connections for leaks each time you connect and disconnect the LP gas supply cylinder. See “Installation Instructions” section.
- When the outdoor cooking gas appliance is not in use, the gas must be turned off at the supply cylinder.
- Storage of an outdoor cooking gas appliance indoors is permissible only if the cylinder is disconnected and removed from the outdoor cooking gas appliance.
- Cylinders must be stored outdoors and out of the reach of children and must not be stored in a building, garage, or any other enclosed area.
- The pressure regulator and hose assembly supplied with the outdoor cooking gas appliance must be used. A replacement pressure regulator and hose assembly specific to your model is available from your outdoor cooking gas appliance dealer.
- Gas cylinder must include a collar to protect the cylinder valve.
- For appliances designed to use a CGA791 Connection: Place a dust cap on cylinder valve outlet whenever the cylinder is not in use. Only install the type of dust cap on the cylinder valve outlet that is provided with a cylinder valve. Other types of caps or plugs may result in leakage of propane.

If the following information is not followed exactly, a fire causing death or serious injury may occur.

- Do not store a spare LP gas cylinder under or near this outdoor cooking gas appliance.
- Never fill the cylinder beyond 80 percent full.

SAVE THESE INSTRUCTIONS

UNPACKING INSTRUCTIONS

1. Using a utility knife, cut the tape to open the top flaps of the carton.
2. Remove the Assembly/ Installation Instructions and Use and Care Guide.
3. Remove the cardboard panel on the top. Remove the corner supports on the top of the inside of the carton. Remove the foam from the two sides
4. Remove the cart base panel from the top and remove all the parts along the front and sides of the carton.
5. Remove the bread warmer, the rotisserie spit, and spare tank barrier bar
6. Remove the foam packaging from the top and sides of the grill head assembly.
7. Remove the four corner supports from the inside of the carton.
8. Using a utility knife, cut along the vertical dotted cut lines located on 2 sides of the carton. Lay the box sides flat.
9. Using two or more people, remove grill head assembly from carton with the foam underneath the grill assembly.

10. Remove the plastic bag from the grill head.

⚠ WARNING

Excessive Weight Hazard

**Use two or more people to move and install grill.
Failure to do so can result in back or other injury.**

11. Remove screws (with hang tags attached) located on either side of the grill head.
12. Open hood remove and open the box which contains the grill component parts. Remove all packaging materials and set component parts aside.
13. Remove wrapped flavor grids from top of box. Open box and remove contents, then set aside.
14. Dispose of/recycle all packaging materials.

ASSEMBLY REQUIREMENTS

Parts Supplied

View of Unassembled Grill Parts

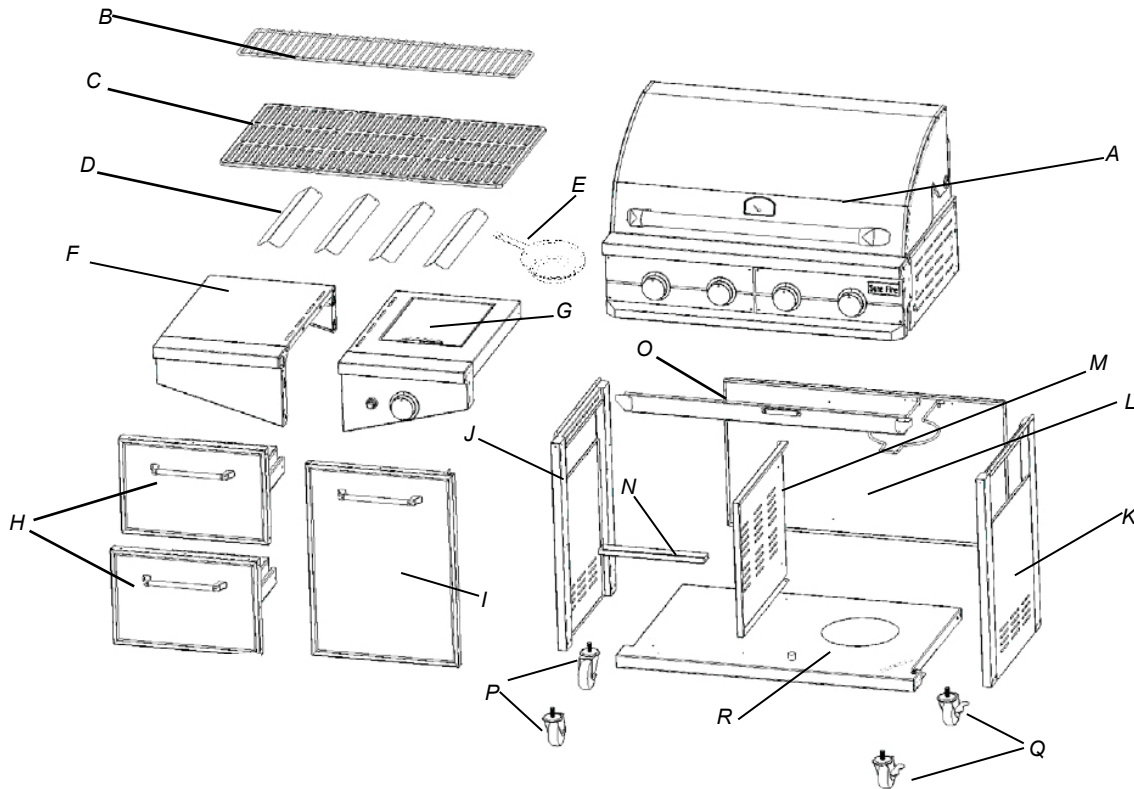

- A. Grill hood assembly
- B. Bread warming rack
- C. Main burner grates
- D. Flavor grids
- E. Side shelf
- F. Side burner shelf
- G. Drawers

- H. Cart door right
- J. Cart left
- L. Cart back
- K. Cart right
- M. Cart base
- N. Drip pan

*Not shown:
Package of small components*

Assembly Hardware Supplied

- 43 - Self-Tapping screws
- 6 - Phillips pan head screws M6 x 10
- 8 - Phillips pan head screws M6 x 40
- 2 - Phillips sunken head screws
- 1 - Side burner knob with bezel
- 1 - "AA" battery
- 1 - Caster Swivel assembly wrench
- 3 - Towel bars

NOTE: Other hardware required is attached to the grill where needed.

Tools Needed

- # 2 Phillips screwdriver
- Tape Measure
- Adjustable wrench
- Level
- 1/2" wrench or socket
- 1/4" nut driver or socket
- Non-corrosive leak detection solution

Parts Supplied

- Gas pressure regulator/hose assembly set for 11" WCP LP gas (attached to manifold).

Parts Needed

- 20 lb LP gas fuel tank

Assembled Grill View

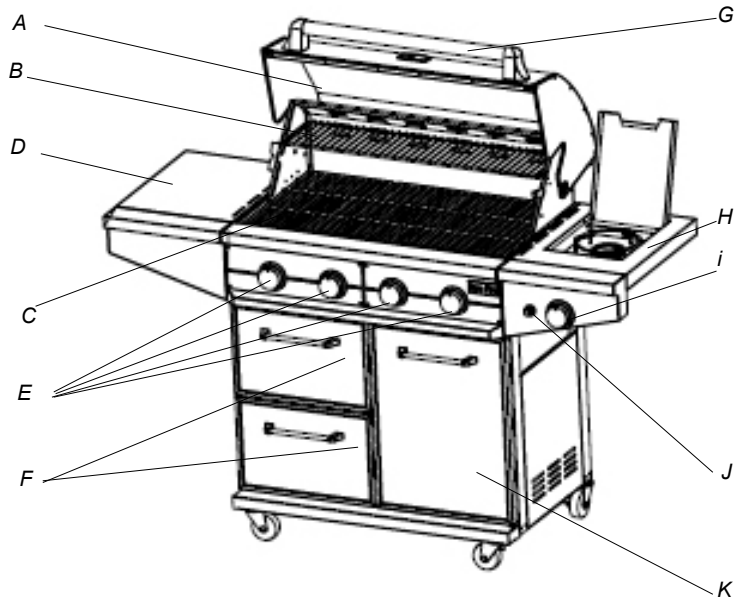

A. Roll top grill hood
B. Bread warming rack
C. Grilling/Cooking Surface
D. Side Shelf
E. Control knobs: Main burners
F. Drawers

G. Hood handle
H. Side Burner
I. Control Knob: Side Burner
J. Electronic Igniter: main burners and side burner
K. Cart Door

ASSEMBLY INSTRUCTIONS

Assemble cart sides

1. Use four (4) Phillips pan head screws M6 x 40 to secure the cart side left to the cart base.
2. Use four (4) Phillips pan head screws M6 x 40 to secure the cart side left to the cart base.

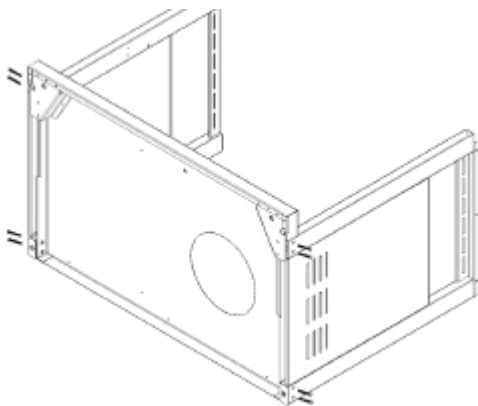

Assemble wheels

1. Use the Caster Swivel assembly wrench to screw the wheels to the cart base. The Caster Swivels with lock should be on the right side.

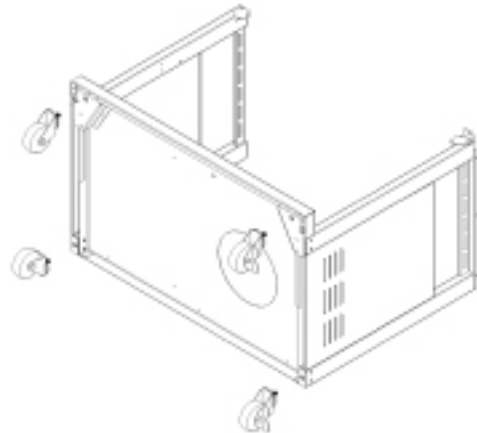

Assemble cart back

1. Tilt the grill cart assembly up. Use six (6) self-tapping screws to secure the cart back to the cart base.

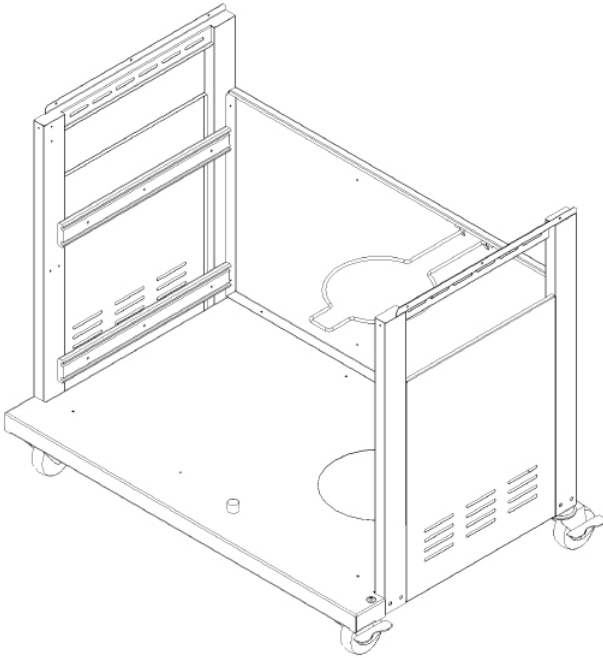

Assemble middle bar

1. Place the middle bar between left cart and cart middle, and then tighten the four (4) self-tapping screws to fix it.

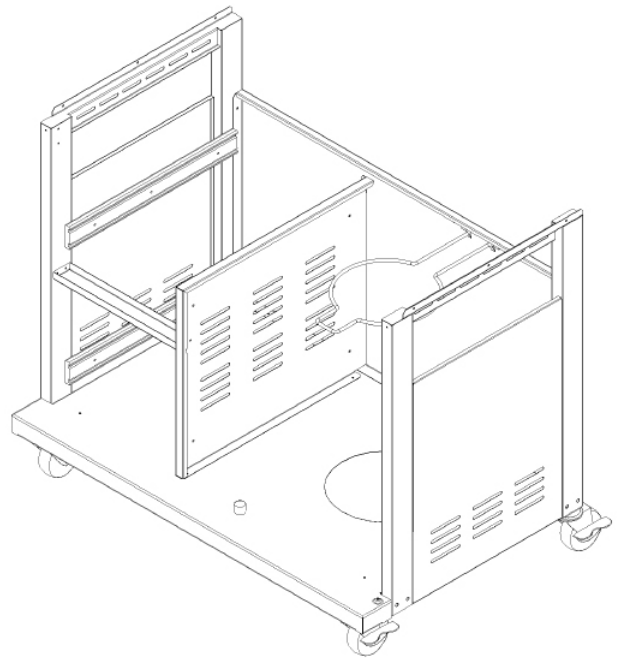

Assemble cart middle

1. Use two (2) self-tapping screws to install the cart middle to the cart back.
2. Then use two (2) self-tapping screws to install the middle cart to the cart bottom.

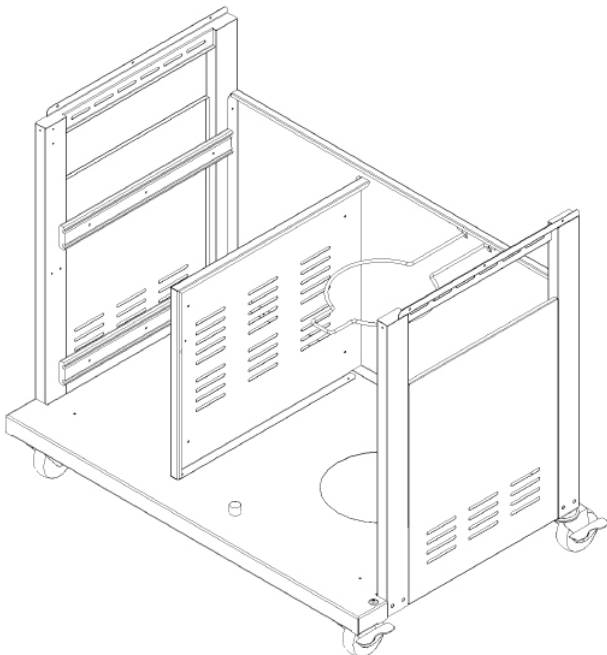

Assemble front top rail

1. Use two (2) Phillips sunken head screws to secure the front top rail onto the cart sides.

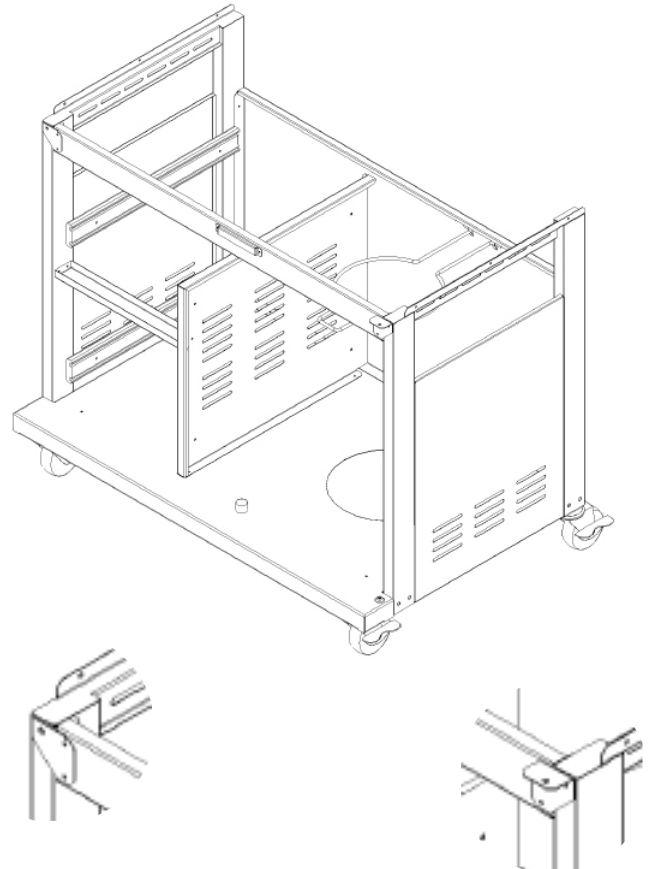

Assemble the drawers

1. Lay the drawer on the floor, and use one Phillips pan head screw M6 x 10 to attach one of the handle ends to the front of the drawer.
2. Slide one end of the towel bar into the installed handle end. Attach the second towel bar handle end using one Phillips pan head screw M6 x 10 while holding the drawer in place.
3. Then use six (6) self-tapping screws to fix the drawer.
4. Repeat this to attach the towel bar to another drawer.

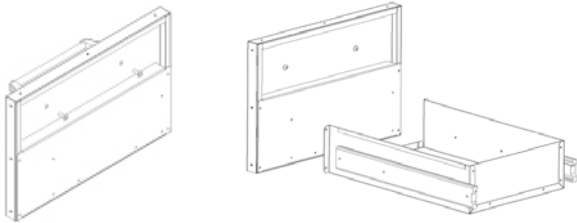

5. Place the drawers evenly between the cart side and cart middle, then make the two sides of the drawer move smoothly with the slot.

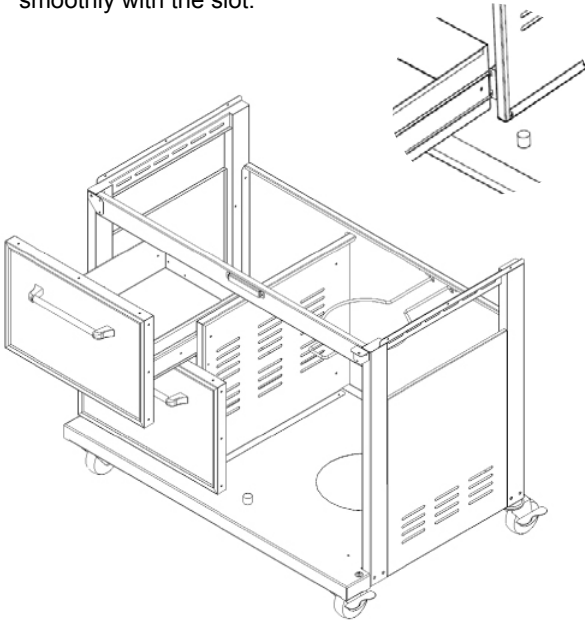

3. Tilt the top of the door toward the grill while depressing the top door pivot pin.
4. Move the door slightly until the pin snaps into place in the hole at the bottom of the front face.

NOTE: The levels of the door may be adjusted using the nuts on the pivot points.

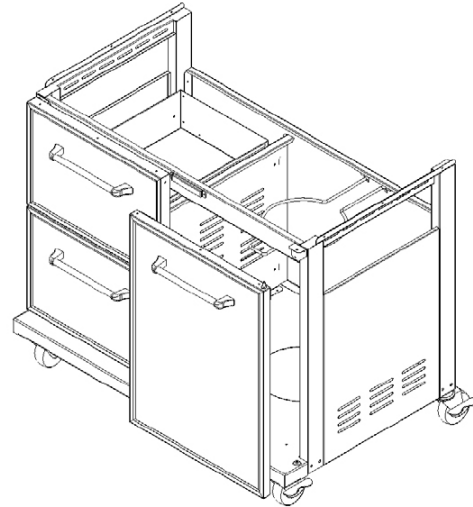

Assemble grill head to cart assembly

1. With the help of a second person, lift the grill head up and set on the top of the grill cart.
2. Use Six (6) self-tapping screws to secure the grill head on the top of the cart sides.

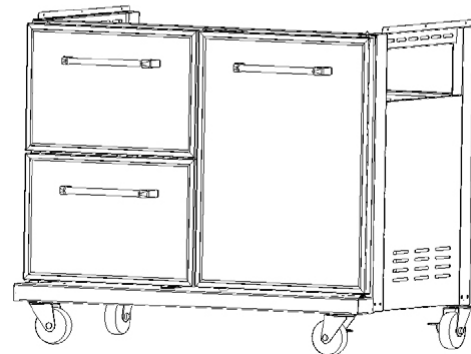
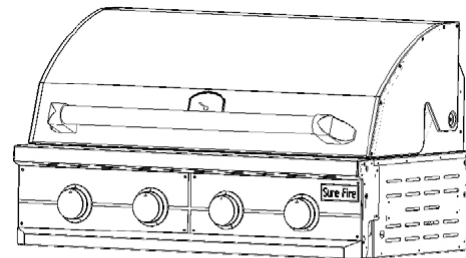

Assemble door to cart

1. Use one Phillips pan head screw M6 x 10 to attach one of the handle ends to the front of the door.
2. Slide one end of the towel bar into the installed handle end. Attach the second towel bar handle end using one Phillips pan head screw M6 x 10 while holding the door in place.

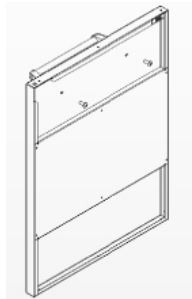

Assemble side shelf

1. Lay the side shelf left assembly on its side. **NOTE: Be careful not to scratch the sides of the shelf.**
2. Place a piece of styrofoam from the packaging inside the roll top hood propped open slightly.
3. Loosen four bolts on the left of the grill head assembly by approximately 1/4".
4. Press the shelf against the grill and press downward until the shelf locks in place. Make sure the top trim strip is hanging all the way inside of the grill before pressing downward.
5. Install 1 self-tapping screw into the bottom front hole under the shelf.
6. Secure the four bolts on the left of the grill head assembly.

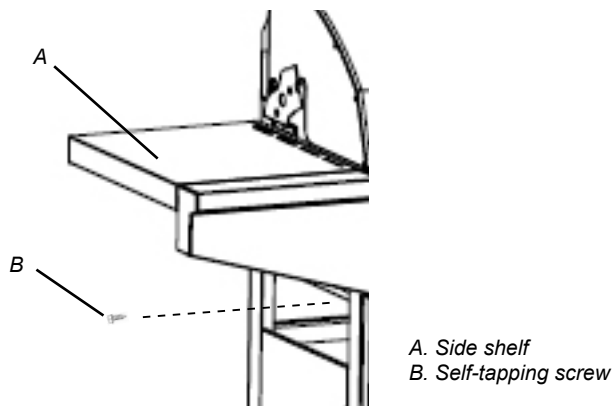

Assemble side burner assembly

1. Feed the side burner gas supply hose assembly through the hole in the side of the cart.
2. Loosen four bolts on the right of the grill head assembly by approximately 1/4".
3. Press the side burner shelf against the grill and press downward until the shelf locks in place. Make sure the top trim strip is hanging all the way inside of the grill before pressing downward.
4. Install 1 self-tapping screw into the bottom front hole under the shelf.
5. Secure the four bolts on the right of the grill head assembly.

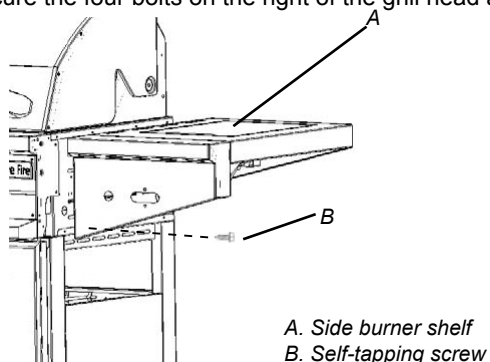

6. Secure the large holding bracket (A) on the side burner assembly with two (2) self-tapping screws.
7. Insert the side burner casting (B) into the holding bracket of the side burner assembly with two (2) self-tapping screws. Then secure the small holding bracket (C) with two (2) self-tapping screws.

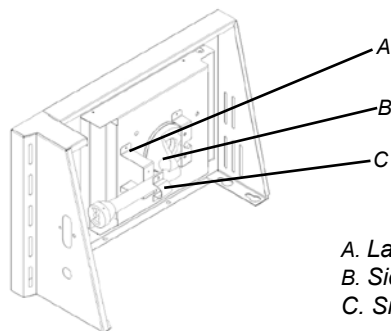

8. Locate the side burner valve assembly out from underneath the control panel.
9. Using a Phillips screwdriver, remove the 2 screws from the side burner valve assembly. Set aside the screws.
10. Push the valve stem out through the opening in the front of the side burner shelf, lining up the threaded holes in the side burner valve assembly with the openings on the side burner shelf.
11. Position the side burner bezel (A) into place with the OFF position facing up, making sure to align the holes.
12. Attach the side burner bezel to side burner assembly face with screws removed in Step 2.
13. Press knob (B) onto valve assembly stem with OFF position facing up.

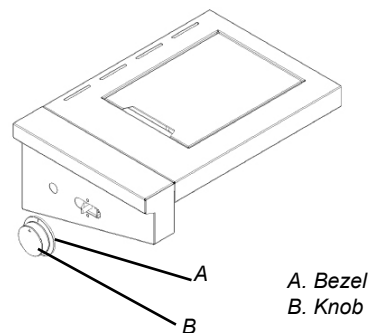

Assemble igniter assembly

1. Place the electronic igniter into the igniter hole on the front left of the side burner shelf. To help ease the installation of the wires, make certain that the igniter wire tabs are facing away from the grill.
2. Secure the igniter in place.
3. Install "AA" battery, negative end (-) first.
4. Install spring and cap assembly and tighten securely.
5. Attach loose wire to bottom of IR burner, and then to any of the open tabs in the igniter. Insert the 6 igniter wires, fed through the grommeted hole on side of grill cart in Step 2 of the "Assemble Side Burner Shelf" section, into the remaining 2 holes.

NOTE: The igniter is designed in such a way that it does not matter which terminal tab is used when connecting igniter wires.

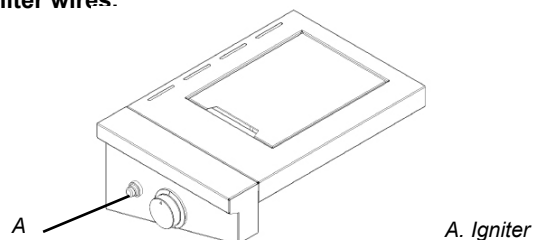

Complete grill assembly

1. Place the side burner cap and grate on to the side burner tray.

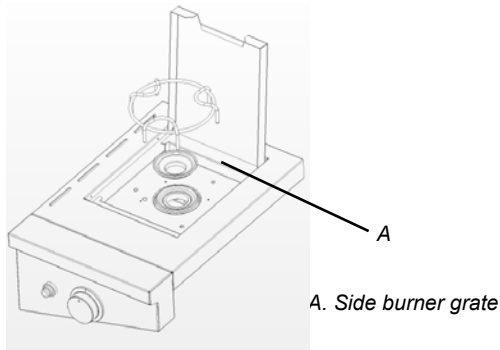

2. Attach the drip pan holder to two holding brackets. Then slide drip pan into place.

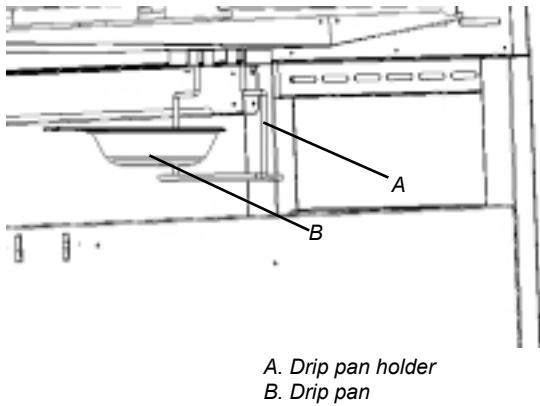

3. Insert the flavor grids into the cutouts with triangle ridges facing up.
4. Install main cooking grates on the ledges provided on the grill to create your cooking surface.
5. Attach rear igniter shield using 2 self-tapping screws.
6. Rest bread warming grate on 4 slots above cooking grid.

NOTE: The finished grill should look like the photo shown on page 6 in the "Assembled Grill View" section.

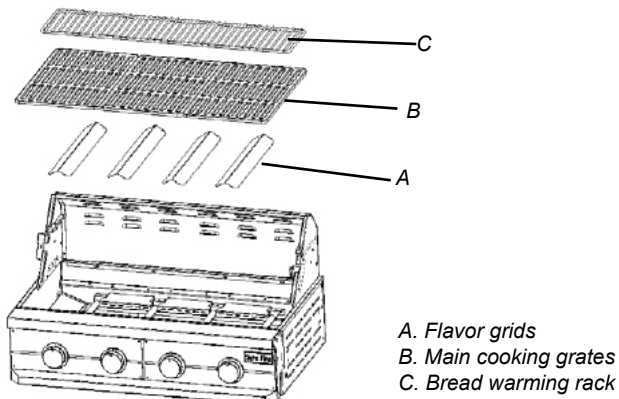

INSTALLATION REQUIREMENTS

Location Requirements

⚠ WARNING



Explosion Hazard

Do not store food tank in a garage or indoors.
Do not store grill with fuel tank in a garage or indoors.
Failure to follow these instructions can result in death, explosion, or fire.

⚠ WARNING



Fire Hazard

Do not use grill near combustible materials.
Do not store combustible materials near grill.
Doing so can result in death or fire.

Select a location that provides minimum exposure to wind and traffic paths. The location should be away from strong draft areas.

Do not obstruct flow of combustion and ventilation air.

Clearance to combustible construction:

A minimum of 24" (61.0 cm) from grill hood sides and back must be maintained from any combustible construction.

Product dimensions

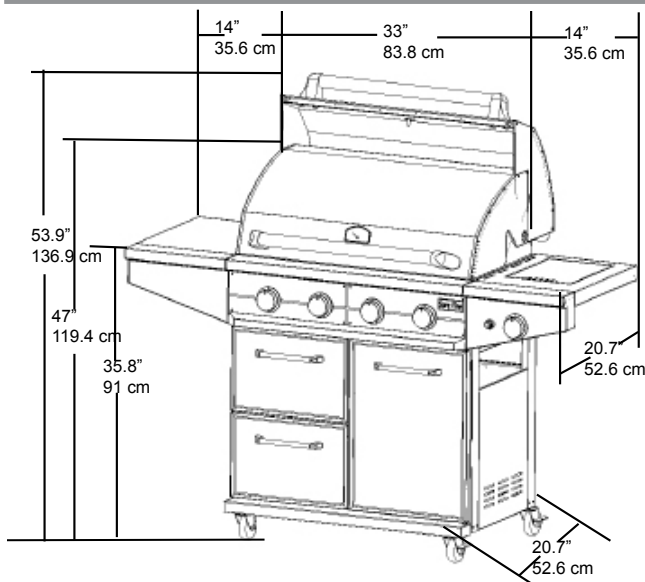

Gas Supply Requirements

Observe all governing codes and ordinances.

IMPORTANT: This installation must conform with all local codes and ordinances. In the absence of local codes, installation must conform with American National Standards Institute, National Fuel Gas Code ANSI Z223.1 - latest edition.

IMPORTANT: Grill must be connected to a regulated gas supply.

Gas Pressure Regulator

The gas pressure regulator supplied with this grill must be used. The inlet (supply) pressure to the regulator should be as follows for proper operation:

LP Gas:

Operating pressure: 11" (27.9 cm) WCP

Inlet (supply) pressure: 11" to 14" (27.9 cm to 35.5 cm) WCP

Contact local gas supplier if you are not sure about the inlet (supply) pressure.

Gas Connection Requirement

20 lb LP Gas Fuel Tank

This grill is equipped for use with a 20 lb LP gas fuel tank (fuel tank not supplied). A gas pressure regulator/hose assembly is supplied.

The 20 lb LP gas fuel tank must be mounted and secured.

1. From the rear of the cart, set a 20 lb LP gas fuel tank into the hole in the cart base.
2. Place the 20 lb LP gas fuel tank retention bar onto the 20 lb LP gas fuel tank.

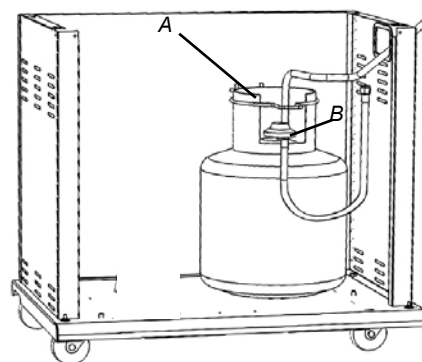

INSTALLATION INSTRUCTIONS

Gas Connection Requirements

⚠ WARNING



Explosion Hazard

Do not store fuel tank in a garage or indoors.

Do not store grill with fuel tank in a garage or indoors.

Failure to follow these instructions can result in death, explosion, or fire.

LP Gas:

IMPORTANT: A 20 lb LP gas fuel tank must be purchased separately.

IMPORTANT: The gas pressure regulator/hose assembly supplied with the grill must be used. Replacement gas pressure regulator/hose assembly specific to your model, is available from your outdoor grill dealer.

To Install the 20 lb LP Gas Fuel Tank:

1. Set tank in hole in the cart base.
2. Screw the gas pressure regulator/hose assembly on to the 20 lb LP gas fuel tank as shown
3. Place the 20 lb LP gas fuel tank secure ring over the collar of the tank as shown.

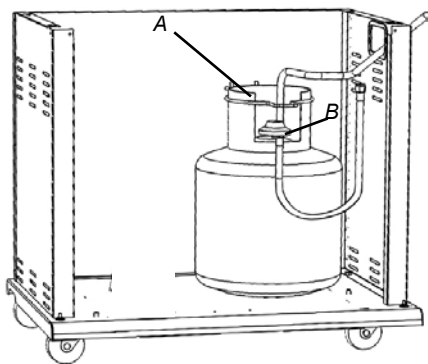

A. Gas pressure regulator/hose assembly

NOTE: The 20 lb LP gas fuel tank orientation shown in the illustration above must be followed to provide proper vapor withdrawal.

4. Turn on the gas supply. Wait a few minutes for gas to move through the gas line.
5. Test all connections by brushing on an approved noncorrosive leak detection solution. Bubbles will show a leak. Correct any leak found.

Check the Burners

The burners are tested and factory-set for most efficient operation. However, variations in gas supply and other conditions may make minor adjustments to air shutter or low flame setting necessary.

It is recommended that a qualified person make burner adjustments.

Checking the grill burner flames requires removing the grate and flavor grids.

Burner Flame Characteristics

The flames of the grill burners and side burners (on some models) should be blue and stable with no excessive noise or lifting (LP gas flames will have a slightly yellow tip). A yellow flame indicates not enough air. If flame is noisy or lifts away from the burner, there is too much air. Some yellow tips on flames when the burner is set to HI setting are acceptable as long as no carbon or soot deposits appear.



Check that burners are not blocked by dirt, debris, insect nests etc. and clean as necessary.

OUTDOOR GRILL USE

This manual covers several different models. The grill you have purchased may have some or all of the features listed. The locations and appearances of the features shown here may not match those of your model.

Control Panel

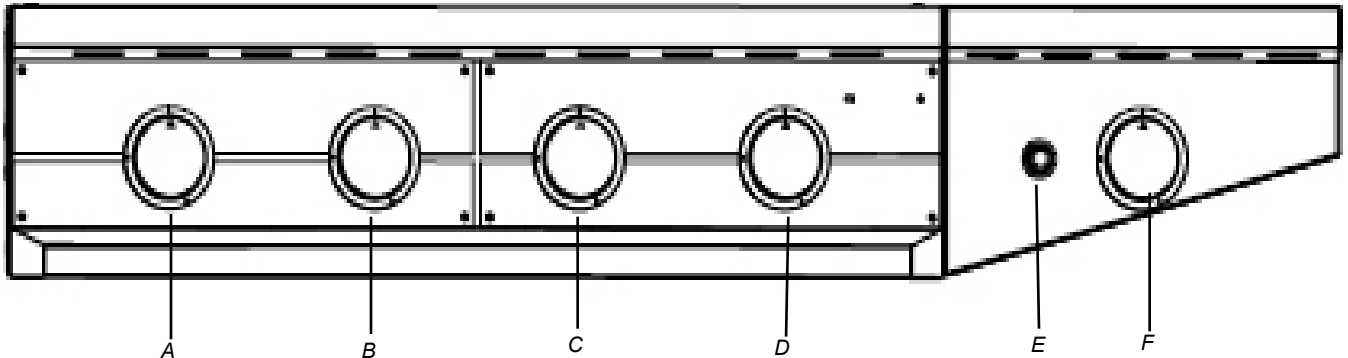

- A. Main Burner Control Knob 1
- B. Main Burner Control Knob 2
- C. Main Burner Control Knob 3
- D. Main Burner Control Knob 4
- E. Igniter Button
- F. Side Burner Control Knob

Using Your Outdoor Grill

⚠ WARNING



Explosion Hazard

**Do not store food tank in a garage or indoors.
Do not store grill with fuel tank in a garage or indoors.
Failure to follow these instructions can result in death, explosion, or fire.**

⚠ WARNING



Fire Hazard

**Do not use grill near combustible materials.
Do not store combustible materials near grill.
Doing so can result in death or fire.**

⚠ WARNING

Food Poisoning Hazard

**Do not let food sit for more than one hour before or after cooking.
Doing so can result in food poisoning or sickness.**

Inspect the LP Gas Fuel Tank Supply Hose

Inspect the gas pressure regulator/hose assembly before each use.

1. Inspect the gas pressure regulator /hose assembly for cuts, abrasions, or excessive wear.
2. If necessary, replace the gas pressure regulator/hose assembly before using the grill.

Contact the dealer and use only replacement hoses specified for use with the grill.

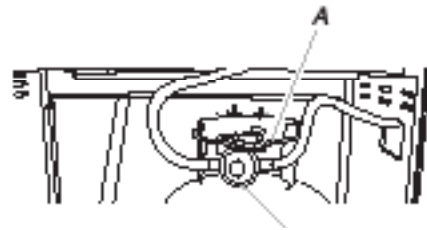

A. Gas pressure regulator/hose assembly

Prepare the Gas Supply

1. Open the hood completely. Do not light burners with the hood closed.
2. Make sure control knobs are turned to "OFF".

Turn the Gas Supply On

1. For outdoor grills using a 20 lb. LP gas fuel tank: Slowly open the tank valve.

NOTE: If flow limiting device activates, your grill may not light. If your grill does not light, the flames will be low and will not heat properly. Turn tank valve and all control knobs off and wait 30 seconds. After shutting off the tank, very slowly open tank valve and wait 5 seconds before lighting.

Lighting the Grill

1. Do not lean over the grill.
2. Push in and turn any grill burner control knob to HIGH, and immediately press the electronic igniter button.

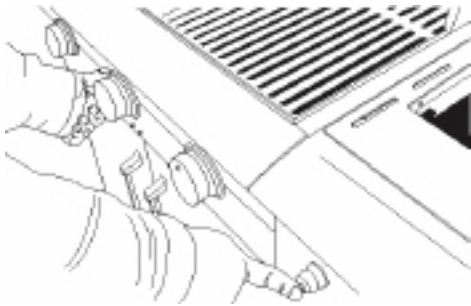

3. You will hear the “snapping” sound of the spark igniter. When burner is lit, release the knob. Turn knob to desired setting.
4. Repeat steps 2 and 3 to light the other burners.

IMPORTANT: If burner does not light immediately, turn the burner knob to OFF and wait 5 minutes before relighting.

Manually Lighting the Grill

1. Do not lean over the grill.
2. Remove the manual lighting extension and attach a match to the split ring.
3. Strike the match to light it.
4. Guide the lit match between the grill grate and one of the slots in the flavor grid near the burner to be lit.

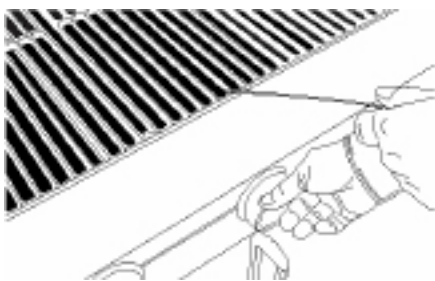

5. Push in and turn the burner knob to HIGH. The burner will light immediately. When burner is lit, turn knob to desired setting.

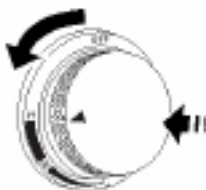

6. Repeat steps 3 through 5 to light the other burners.

7. Remove match and replace manual lighting extension.

IMPORTANT:

If burner does not light immediately, turn the burner knob to OFF and wait 5 minutes before relighting.

If any burners do not light after attempting to light them manually, contact customer service. See the “Assistance” section.

Using Your Side Burner

⚠ WARNING



Burn Hazard

Do not let the burner flame extend beyond the edge of the pan.

Doing so can result in burns

Lighting the Side Burner

1. Open the side burner cover. Do not light burners with the cover on.
2. Do not lean over the grill.
3. Push in and turn the control knob to HIGH and immediately press the electronic igniter button.



4. You will hear the “snapping sound of the spark igniter. When burner is lit, release the knob. Turn knob to desired setting.

IMPORTANT: If burner does not light immediately, turn the burner knob to OFF and wait 5 minutes before relighting.

Manually lighting the side burner

1. Do not lean over the grill.
2. Remove the manual lighting extension and attach a match to the split ring.
3. Strike the match to light it.
4. Guide the match to the burner

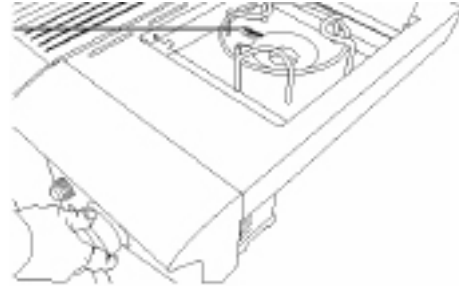

5. Push in and turn the burner knob to HIGH. The burner will light immediately. When the burner is lit, turn knob to desired setting.



6. Remove match and replace manual lighting extension.

IMPORTANT:

If burner does not light immediately, turn the burner knob to OFF and wait 5 minutes before relighting.

If any burners do not light after attempting to light them manually, contact customer service. See the “Assistance” section.

OUTDOOR GRILL CARE

Replacing the Igniter Battery

If igniters stop sparking, the battery should be replaced.

1. Unscrew igniter button cap counter-clockwise to remove.

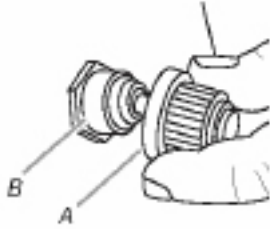

A. Igniter push button
B. "AA" size battery

2. Remove battery from the battery compartment.
3. Replace with a new alkaline "AA" size battery. Install battery with negative end (-) in first.
4. Screw igniter button cap clockwise into place.

General Cleaning

IMPORTANT: Before cleaning, make sure all controls are off and the grill is cool. Always follow label instructions on cleaning products.

For routine cleaning, wash with soap and water using a soft cloth or sponge. Rinse with clean water and dry at once with a soft, lint-free cloth to avoid spots and streaks.

To avoid scratching the surface, do not use steel wool to clean the grill.

To avoid damage from the weather, use a vinyl grill cover, available from your local dealer.

STAINLESS STEEL

IMPORTANT: To avoid damage to the stainless steel surface, do not use soap-filled scouring pads, abrasive cleaners, cooktop polishing creme, steel wool, gritty wash cloths, paper towels or cleaners that contain chlorine.

Food spills should be cleaned as soon as entire grill is cool. Spills may cause permanent discoloration.

Cleaning Method:

- Rub in direction of grain to avoid scratching or damaging the surface.
- Stainless Steel Cleaner.
- Liquid detergent or all-purpose cleaner.
- Rinse with clean water and dry with soft, lint-free cloth.
- Glass cleaner to remove fingerprints.

PORCELAIN-COATED PARTS

To avoid chipping, do not bang porcelain covered parts with solid objects or drop them.

Cleaning Method:

- Non-abrasive plastic scrubbing pad and mildly abrasive cleanser.

GRILL GRATES

IMPORTANT: Do not use a steel or fiber scraper on grill grates. Immediately after you are finished cooking, loosen food soil with a brass bristle brush. Turn all burners to HI for 10-15 minutes with the hood closed to burn off food soil. Turn off all burners, raise the hood and let grates cool. Use the brass bristle brush to remove ash from the grill grates.

When completely cool, grill racks can be removed for thorough cleaning. Clean them with a mild detergent and warm water.

For baked-on soil, prepare a solution of 1 cup (250 mL) ammonia to 1 gal. (3.75 L) water. Soak grates for 20 minutes, then rinse with water and dry completely.

WARMING SHELF

Cleaning Method:

- Liquid detergent or an all-purpose cleaner.
- Rinse with clean water and dry with soft, lint-free cloth.
- For tough spots or baked-on grease, use a commercial degreaser designed for stainless steel.

EXTERIOR

IMPORTANT: Make sure gas supply is off and all control knobs are in the OFF position. Make sure the side burner is cool.

The quality of this material resists most stains and pitting, providing that the surface is kept clean, covered, and polished.

- Apply stainless steel polish to all brushed stainless steel non-cooking surfaces before first use. Re-apply after each cleaning to avoid permanent damage to surface.
- For tough spots or baked-on grease, use a commercial degreaser designed for stainless steel.
- Cleaning should always be followed by rinsing with clean warm water.
- Wipe the surface completely dry with a soft cloth.
- Liquid detergent or all-purpose cleaner for all powder coated surfaces.

INTERIOR

Discoloration of stainless steel on these parts is to be expected, due to intense heat from the burners. Always rub in the direction of the grain. Cleaning should always be followed by rinsing with clean, warm water.

Cleaning Method:

- Liquid detergent or all-purpose cleaner or for small, difficult-to-clean areas, use a commercial degreaser designed for stainless steel.
- A heavy-duty scrub sponge can be used with mild cleaning products.
- Rinse with clean water and dry completely with a soft, lint-free cloth.

SIDE BURNER CAPS AND GRATE

Cleaning Method:

- Clean with a brass bristle brush.
- Wash grate using mild detergent, warm water and degreaser.
- Rinse with clean water and dry with soft, lint-free cloth.
- Stainless steel cleaner.

BURNERS

Cleaning Method:

- Clean the exterior of the burner with a wire brush.
- Clear any clogged burner ports with a straightened paper clip. Do not use a toothpick as it may break off and clog the port.
- Check and clean burner/venturi tubes.

DRIP PAN

IMPORTANT: The drip pan should be removed only when grill is completely cool.
The drip pan collects grease that runs out through the grill. Clean often to avoid grease buildup.

Cleaning Method:

- Remove drip pan. Wipe excess grease with paper towels.
- Clean with mild detergent and warm water. Rinse and dry thoroughly.

KNOBS AND FLANGE AREA AROUND KNOBS

IMPORTANT: To avoid damage to the knobs and flange area, do not use steel wool, abrasive cleaners, or oven cleaner.
To avoid damage, do not soak knobs.

Cleaning Method:

- Mild detergent, a soft cloth and warm water.
- Rinse and dry.

CONTROL PANEL GRAPHICS

IMPORTANT: To avoid damage to the control panel graphics, do not use steel wool, abrasive cleaners or oven cleaner.
To avoid damage, do not spray cleaner directly onto panel.

Cleaning Method:

- Clean around the burner labels gently; scrubbing may remove printing.
- Clean with mild detergent, soft cloth and warm water.
- Rinse and dry.

TROUBLESHOOTING

Grill will not light

- **Is the 20 lb LP gas fuel tank valve turned off?**
Turn the 20 lb LP gas fuel tank on.
- **Is the grill properly connected to the gas supply?**
Contact a trained repair specialist or see Installation Instructions.
- **Is there gas in the 20 lb LP gas fuel tank?**
Check the gas level.
- **Is the igniter working?**
Check that the igniter battery is properly installed or check to see if the battery needs to be replaced. See the "Replacing the Igniter Battery" section.

Check for loose wire connections to the igniter or electrodes.

Check to see if debris is blocking the electrodes.

Flame is low or erratic

- **Is the gas supply fully turned on?**
Check that the 20 lb LP gas fuel tank valve is fully open..
- **Is the gas supply in the 20 lb LP fuel gas tank low?**
Check the gas level.
- **Does only one burner appear low?**
Check and clean the burner ports if clogged or dirty. See "General Cleaning" section.
- **Is the burner flame mostly yellow or orange?**
Grill may be in an area that is too windy. Check the burner air inlets for obstructions.

ASSISTANCE

Before calling for assistance, please check "Troubleshooting" section above. If you still need help, follow the instructions below.

When calling, please know the purchase date and the complete model and serial number of your appliance. This information will help us to better respond to your request.

If you need replacement parts:

If you have questions or need replacement parts, contact Customer Service Hotline at **1-800-229-5647** or visit **www.sureheat.com**.

Sure Heat Manufacturing
1861 West Oak Parkway
Marietta, GA 30062

REPLACEMENT PARTS

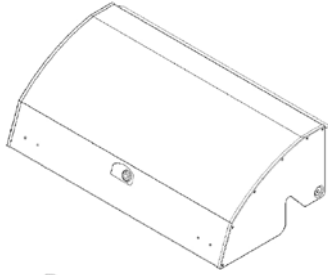

Hood Assembly
SASCD00534B
1 set

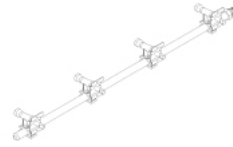

Manifold & Valve Assembly
RCOZZ00532A
1 set



Hood Handle Assembly
SASQG00005A
1 set

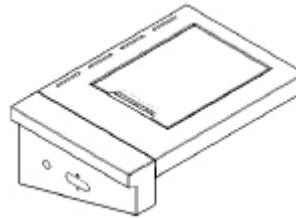

Side Burner Shelf
SASCD00530B
1 set



Temperature Gauge
RCOZZ00029A
1 piece



Large Bezel
RCOAG00003A
1 piece

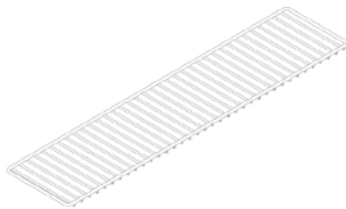

Bread Warming Rack
RCORC00011A
1 piece



Large Knob
RCOFE00001A
1 piece

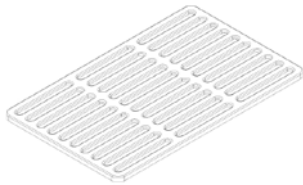

Main Cooking Grate
RCOCC00011A
1 piece

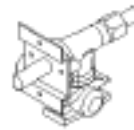

Side Burner Valve Assembly
RCOZZ00323A
1 set



Flavor Grid
SBNMC00392A
1 piece

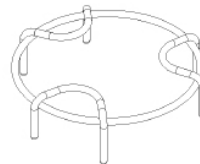

Side Burner Grate
RCOLC00009A
1 piece

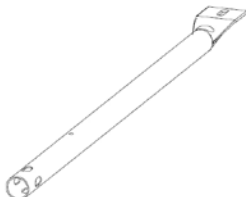

Main Burner Tube
RCOQG00005A
1 piece



Side Burner Casting
RCOZZ00140A
1 piece

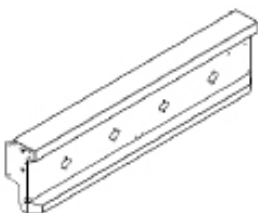

Cart base
SWLCD00535A
1 set



Side Burner Cap
RCOCC00001A
1 piece

REPLACEMENT PARTS

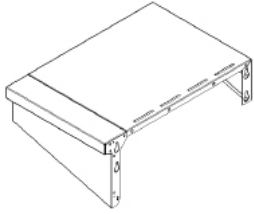

Side Shelf
SASCD00526B
1 set

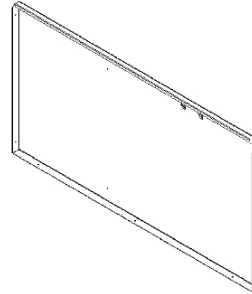

Cart Back
SBNCD00545A
1 set

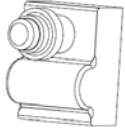

Igniter Right with 5 Poles
RCOZZ00027A
1 piece



Tank Fixing Ring
RCOZE00015A
1 piece



Regulator
RCOZZ00125A
1 set

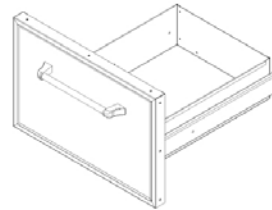

Drawer
SASCD00541A
1 set



Drip Pan
RCOCC00004A
1 piece



Middle bar
SBNJB00213A
1 set

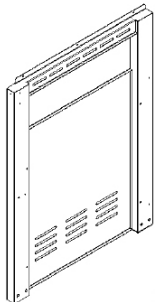

Cart left
SASCD00544A
1 set

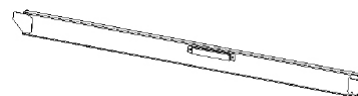

Front Top Rail
SBNCD00546A
1 set



Cart Middle
SBNJB00212A
1 set

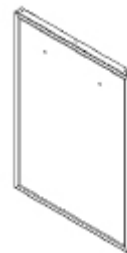

Door
SBNCD00542A
1 set



Cart right
SASCD00544B
1 set



Door handle
SASQG00030A
1 set

REPLACEMENT PARTS

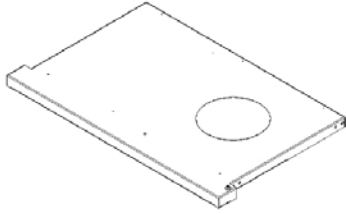

Base
SBNCB00543A
1 set



Caster Swivel With Lock
RCOZZ00218A
1 set



Caster Swivel
RCOZZ00219A
1 set

Not Shown:

RCOZZ00276A

Side Burner Igniter w/ wire 300mm

RCOZZ00313A

Main Burner Igniter w/ wire 400mm

RCOZZ00213A

Main Burner Igniter w/ wire 540mm

RCOZZ00214A

Main Burner Igniter w/ wire 740mm

RCOZZ00215A

Main Burner Igniter w/ wire 920mm

RCOZZ00316A

"Surefire" Logo

LIMITED WARRANTY

Sure Heat Manufacturing warrants that for 2 years from the date of purchase, the stainless panels will not break due to defects in material or workmanship. All other components of this grill are warranted free from defects in material and workmanship for one year from the date of purchase. Sure Heat Manufacturing at its option, will repair or replace this product or any component of the product found to be defective during the warranty period. Replacement will be made with a new manufactured product or component. If the product is no longer available, replacement may be made with a similar product of equal value. This warranty does not include transportation or shipping costs of any kind. This is your exclusive warranty. This warranty is valid for the original retail purchaser from the date of initial retail purchase and is not transferable. Keep the original sales receipt. Proof of purchase is required to obtain warranty parts.

This warranty does not cover normal wear of parts such as scratches and dents of the stainless steel components or damage resulting from any of the following:

- negligent use or misuse of the product, including exposing the product to chemicals or cleaning products not approved by Sure Heat Manufacturing.
- corrosion, rust or discoloring of any kind.
- use or installation contrary to specified instructions and applicable building codes, including heating the product to temperatures above its rated specifications which can cause disassembly, including removal of the product from a built-in installation
- damage resulting from accident, alteration, misuse, abuse, hostile environments, or improper installation
- repair or alteration
- acts of God, such as fire, flood, hurricanes and tornadoes
- gas cylinder, propane tanks or other fuel delivery systems, including connections to a household fuel supply
- usage other than single-family household use such as commercial or industrial use
- minor warping or discoloration of parts, which is normal and not a defect under this warranty

DO NOT RETURN THIS PRODUCT TO THE PLACE OF PURCHASE

If the Grill does not operate properly, first thoroughly carry out the instructions provided with the unit to ensure that the appliance is installed correctly and check the troubleshooting section in the Use and Care Manual.

We recommend you return the warranty registration card so that you can be contacted when any questions of safety arise that could affect you. The return of the warranty registration card is not a condition for warranty coverage.

Because of continuing product improvement these specifications are subject to change without notice.

**If you have other questions or need replacement parts contact our
Customer Service Hotline at 1-800-229-5647 or
visit our website at www.sureheat.com**